

The Norton Commando is a remarkably successful motorcycle, but it has a few design weaknesses. Perhaps the best known of these is the pre-MKIII swing arm bearing assembly. The bronze bushes require more lubrication than they usually get, and the hardened steel spindle is insufficiently supported in the gearbox cradle. The result is excess side play in the swing arm, which in turn degrades the handling of the machine. The usual fix (as detailed in the INOA Tech Notes) requires disassembly of the bearing and welding of some nuts onto the cradle. This is a good permanent fix, but exceeds the workshop capability of most owners.

INOA member Heinz Kegler has developed a repair kit for this problem that is field installable without removing the swing arm or the rear fender. It consists of a pair of split collars that clamp around the swing arm pivot tube of the cradle. A lock bolt is threaded through each collar to clamp the spindle in place.



Here's the procedure I followed to install the kit:

- 1) Put the bike on the center stand. Block the front wheel so that the bike cannot roll forward. This is important for your safety! Remove the rear wheel and oil filter assembly if fitted.
- 2) Mark and center punch for two holes in the spindle support tube. Drill to 17/64 in. as shown in the diagram below. Try to keep the drill perpendicular to the tube while drilling, so the hole doesn't wander. The tip of the drill will blunt itself on the hardened spindle, so you won't be able to drill completely through the tube.

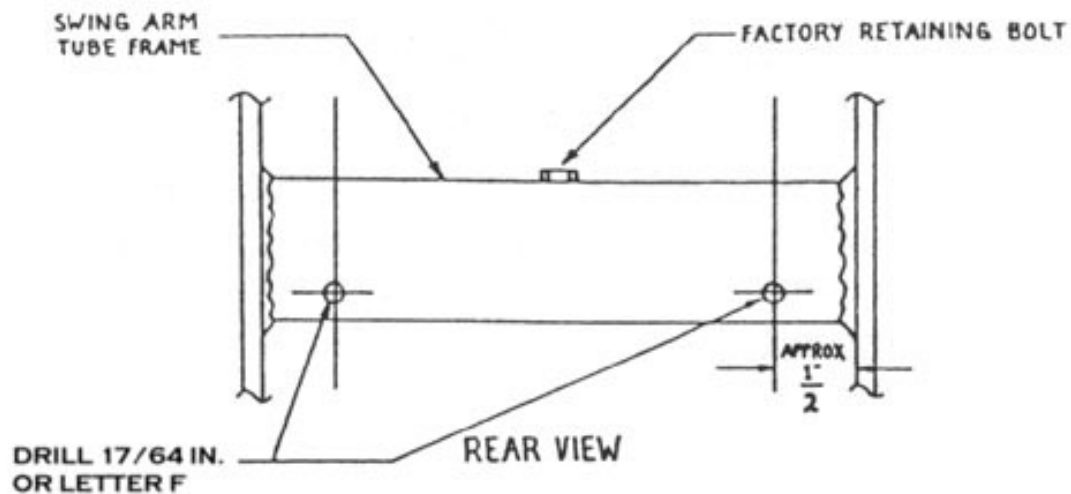

- 3) 'Skin sharpen' the drill by grinding it flat across the tip, or buy a skin sharpened drill at a tool supply house. Using this drill, bottom out the holes against the spindle. There will still be a small burr at the bottom of each hole, but this is OK.

- 4) Loosen the locking bolt in each collar, but leave the end projecting through its threaded hole. Using some loctite on the clamp screws, install each collar. Make sure that each spindle locking bolt is correctly located in the hole you drilled.
- 5) Tighten the spindle locking bolts (about 20 lbs. torque). Finally, tighten the lock nuts on the bolts. Wiggle the swing arm to make sure everything is tight. If you still have too much side movement, the bushes are worn and must be replaced.



- 6) Replace the oil filter assembly (if fitted) and the rear wheel.

Total time for the installation was under three hours. There isn't much that can go wrong, and the quality of the parts is high, so the fix should last as long as the bike. For details, contact Heinz Kegler at (505) 892-8447, or email at [heinz500gp@aol.com](mailto:heinz500gp@aol.com). Finally, I'd like to thank Ken Armann for letting me use his shop airlift for the installation.